

Impedance Issues in SuperKEKB

D. Zhou

With contributions from

KEK: T. Abe, T. Ishibashi, Y. Morita, K. Shibata, Y. Suetsugu,
M. Tobiyama, M. Yoshida, ...

SLAC: Y. Cai, G. Stupakov

The 19th KEKB Accelerator Review Committee, Mar. 03, 2014

Outline

➤ Introduction

- Machine parameters, Tasks definition, ...

➤ Impedance calculations

- Modeling, Pseudo-Green wake function, ...

➤ Loss factors and HOM power

➤ Single-bunch effects

- Longitudinal: Bunch lengthening, Potential-well distortion, MWI, ...

- Transverse: Beam tilt, TMCI, ...

➤ Summary and Future plan

1. Introduction: Machine parameters

2013/July/29	LER	HER	unit	
E	4.000	7.007	GeV	
I	3.6	2.6	A	
Number of bunches	2,500			
Bunch Current	1.44	1.04	mA	
Circumference	3,016.315		m	
ϵ_x/ϵ_y	3.2(1.9)/8.64(2.8)	4.6(4.4)/12.9(1.5)	nm/pm	() : zero current
Coupling	0.27	0.28		includes beam-beam
β_x^*/β_y^*	32/0.27	25/0.30	mm	
Crossing angle	83		mrad	
α_p	3.18×10^{-4}	4.53×10^{-4}		
σ_s	$8.10(7.73) \times 10^{-4}$	$6.37(6.30) \times 10^{-4}$		() : zero current
V_c	9.4	15.0	MV	
σ_z	6.0(5.0)	5(4.9)	mm	() : zero current
v_s	-0.0244	-0.0280		
v_x/v_y	44.53/46.57	45.53/43.57		
U_0	1.86	2.43	MeV	
$\tau_{x,y}/\tau_s$	43.2/21.6	58.0/29.0	msec	
ξ_x/ξ_y	0.0028/0.0881	0.0012/0.0807		
Luminosity	8×10^{35}		$\text{cm}^{-2}\text{s}^{-1}$	

From <http://www-superkekb.kek.jp/index.html>

1. Introduction: Tasks on impedance issues

➤ Impedance calculations

- Tools: Analytical, GdfidL, CST particle studio, ABCI, ...
- Pseudo-Green wake function: $\sigma_z=0.5\text{mm}$

➤ HOM heating

- Loss factors and HOM power
- Heating load and its impact on vacuum components

➤ Single-bunch collective effects

- Longitudinal: Bunch lengthening, potential-well distortion, MWI

- Transverse: Beam tilt, TMCI (mainly y-direction)

➤ Multi-bunch collective effects

- Multi-bunch transverse instability (mainly due to resistive wall impedance)

2. Impedance calculations: Modeling: LER

Bellows

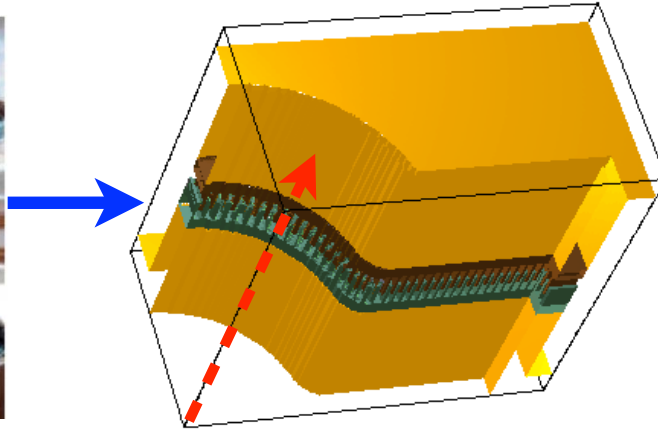
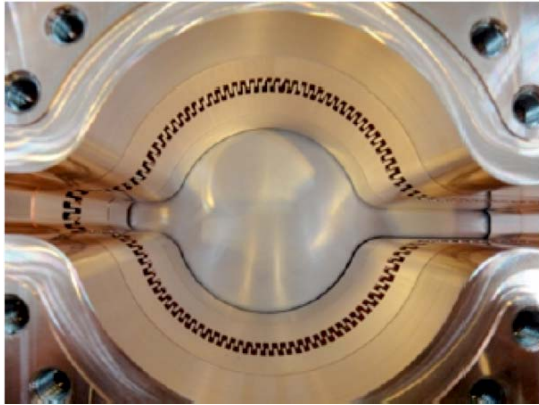

Pumping port

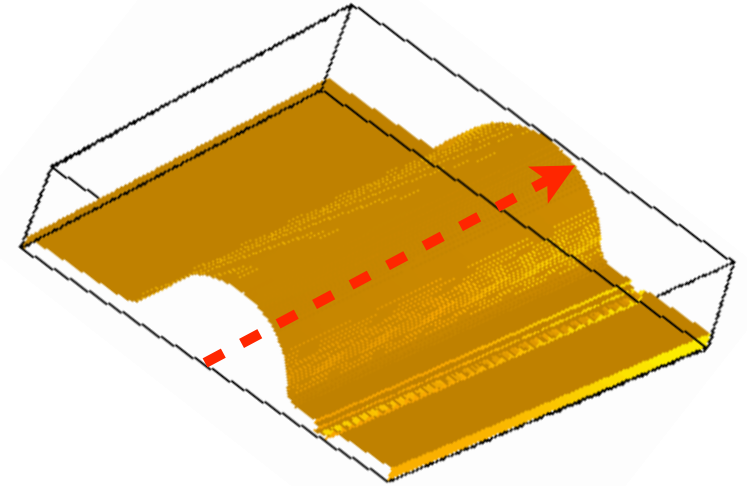

MO-type flange

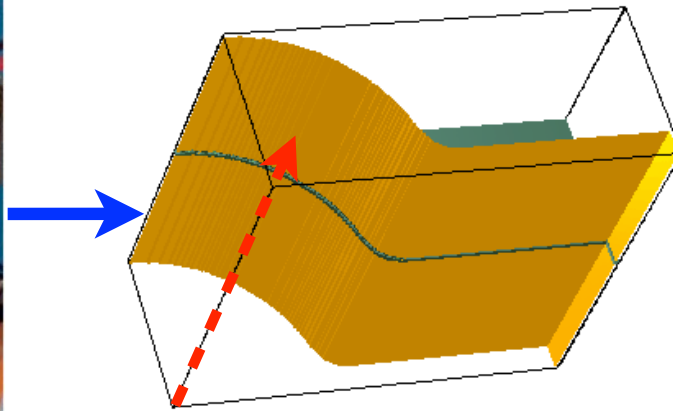
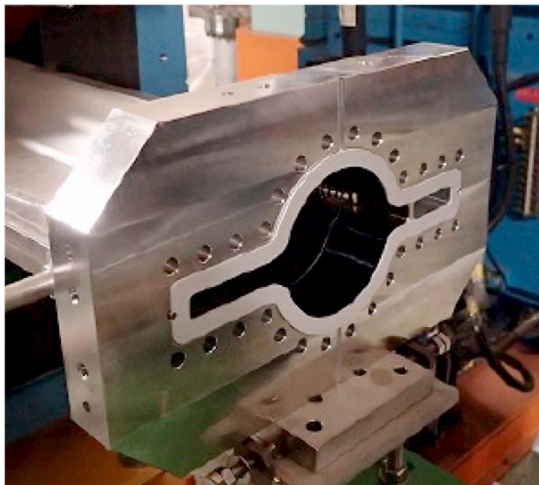

ARES RF cavity

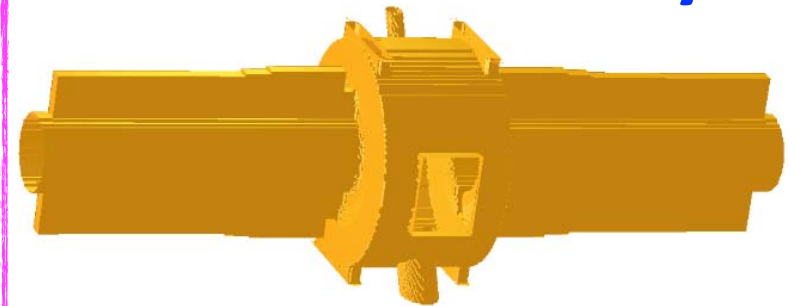

2. Impedance calculations: Modeling: LER

Horizontal

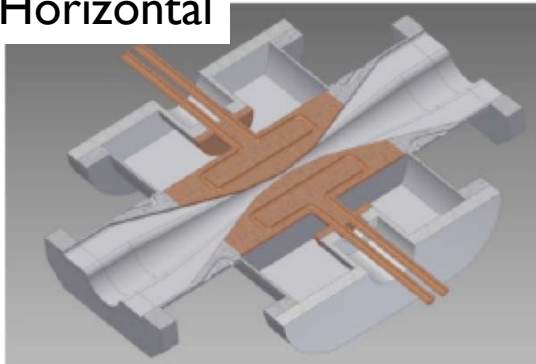

Vertical

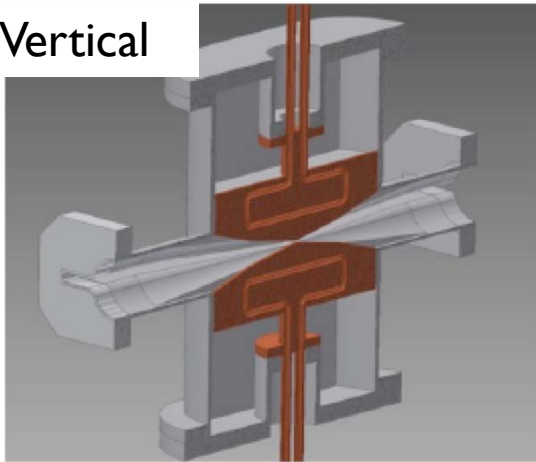

Collimator (PEPII type)

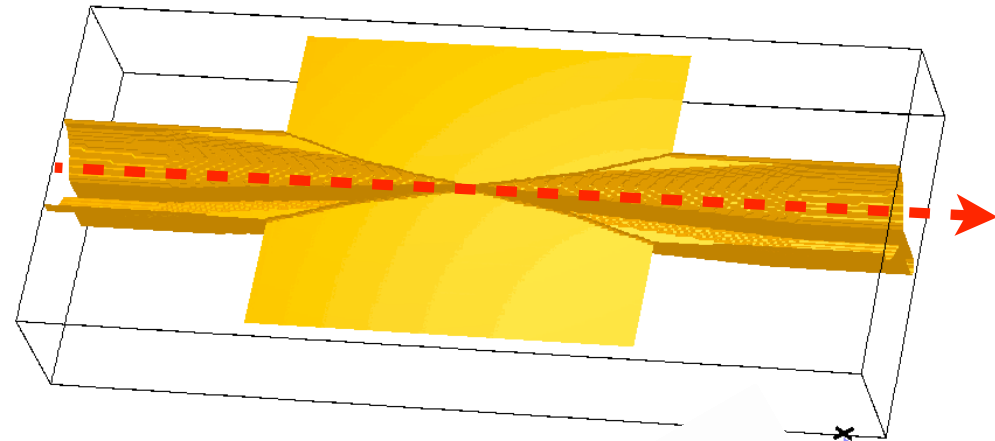
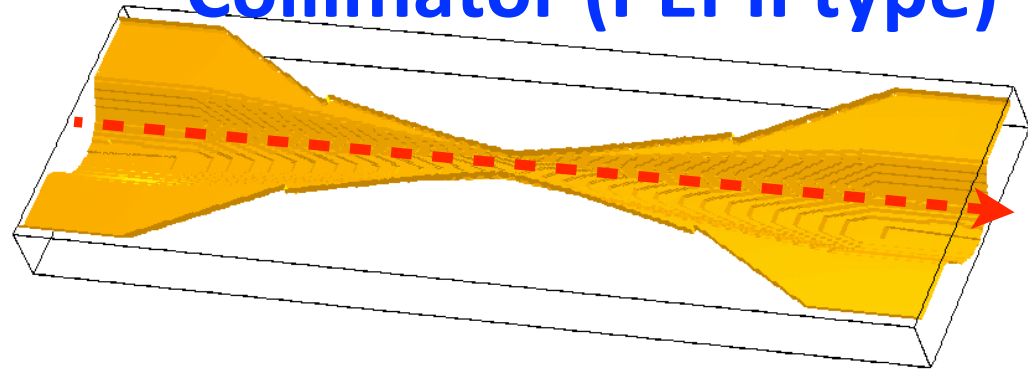

BPM

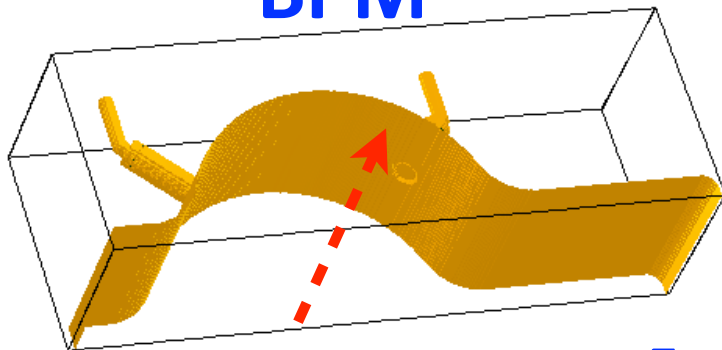

SR mask

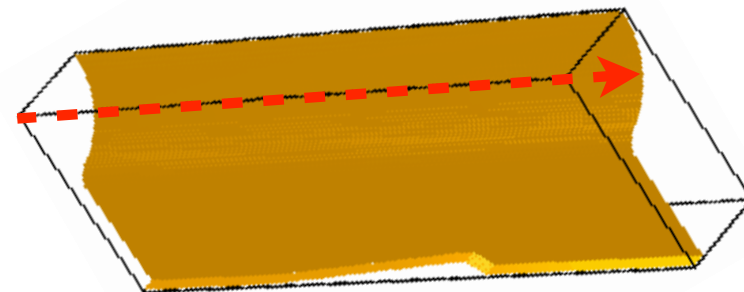

From T. Ishibashi, M. Tobiyaama, and K. Shibata

2. Impedance calculations: Modeling: HER

SCC (by ABCI)

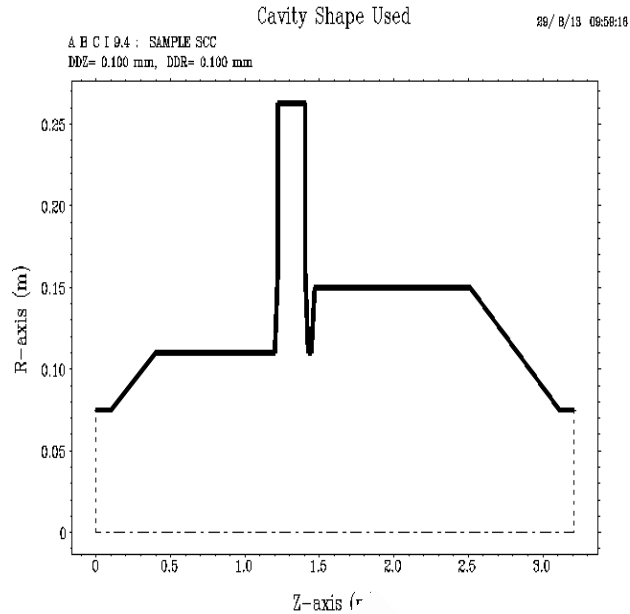

Movable mask (KEKB type)

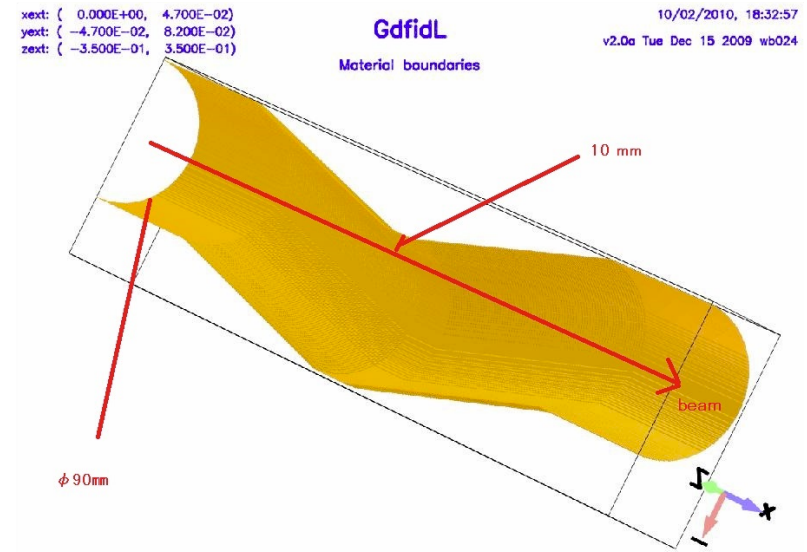

Bellows

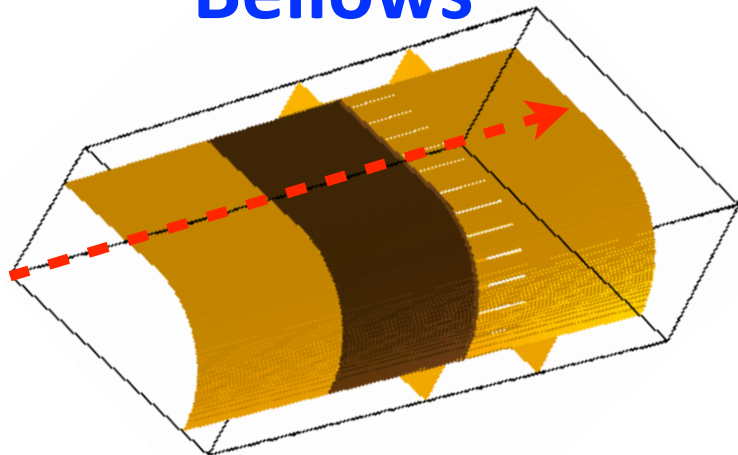

ARES

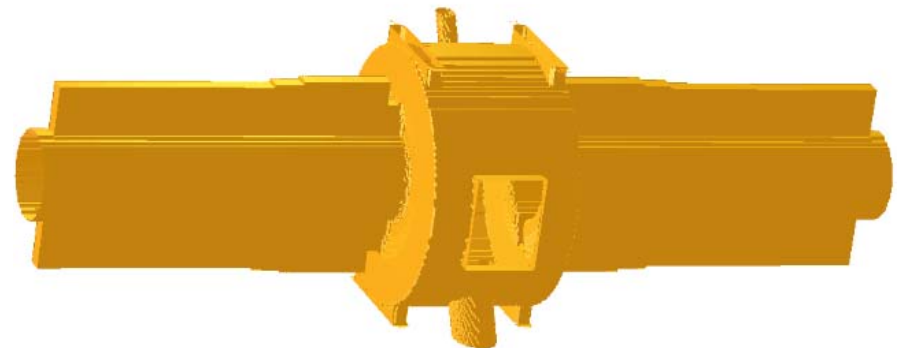

From T. Abe, Y. Morita, and K. Shibata

2. Impedance calculations: Modeling: HER

Pumping port

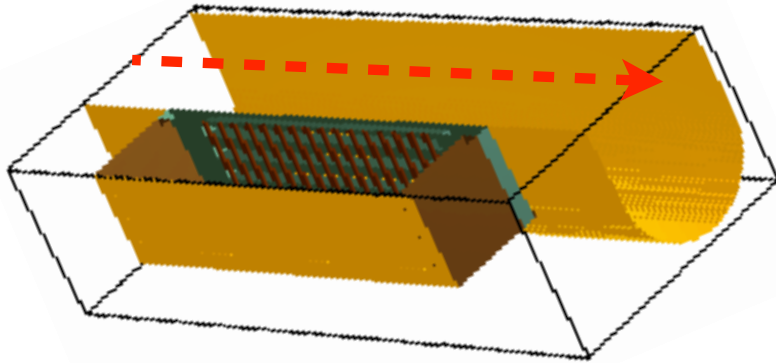

Flange

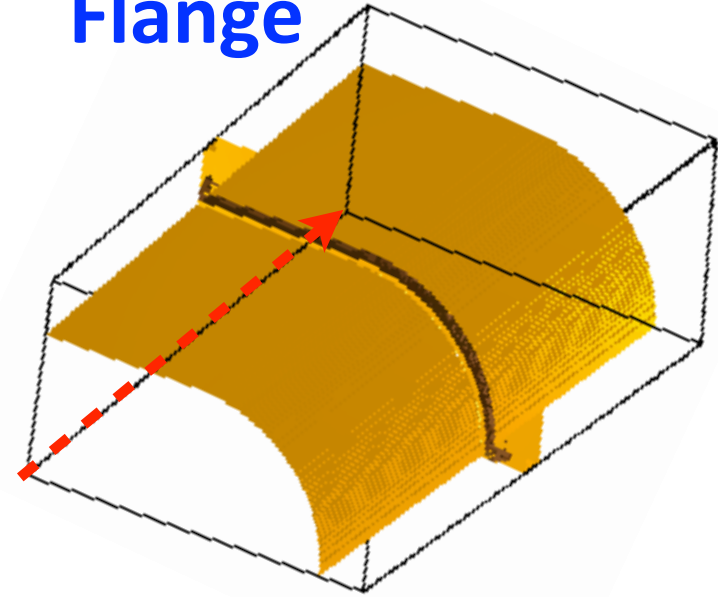

BPM

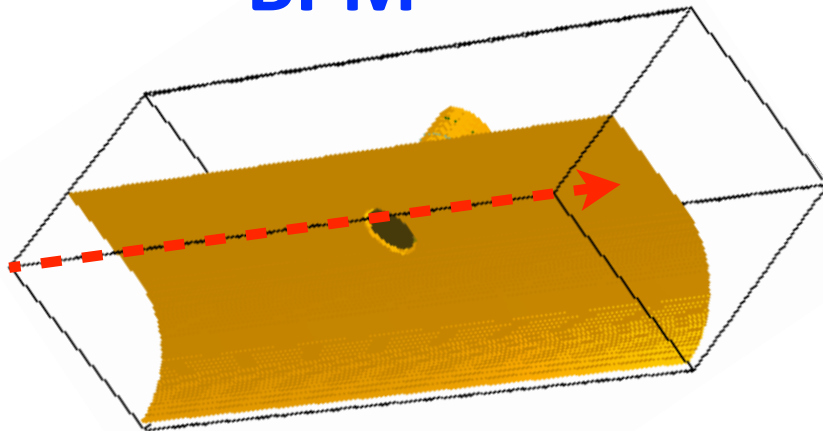

SR mask

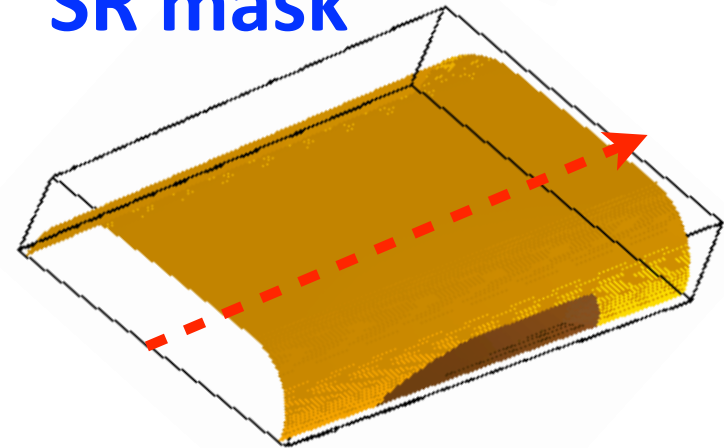

2. Impedance calculations: Results: LER

► Pseudo-Green wake function

- $\sigma_z=0.5\text{mm}$
- Pumping ports and SR masks are negligible sources
- CSR and CWR (Wiggler radiation): CSRZ code with rectangular chamber
- Not considered yet: Gate valves, BxB FB BPMs, Grooves surface, Clearing electrodes

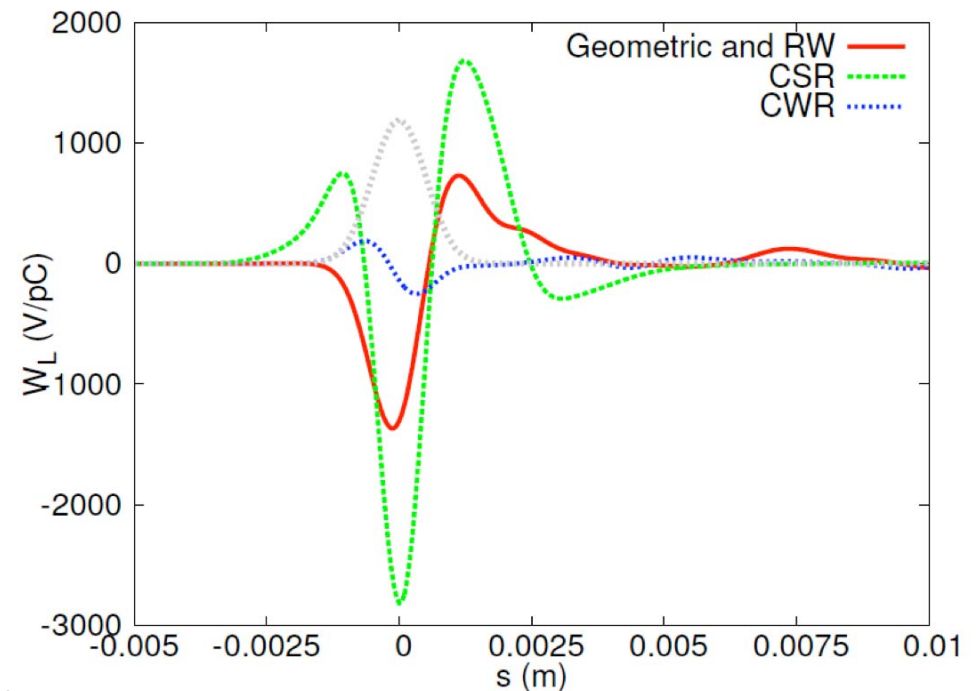
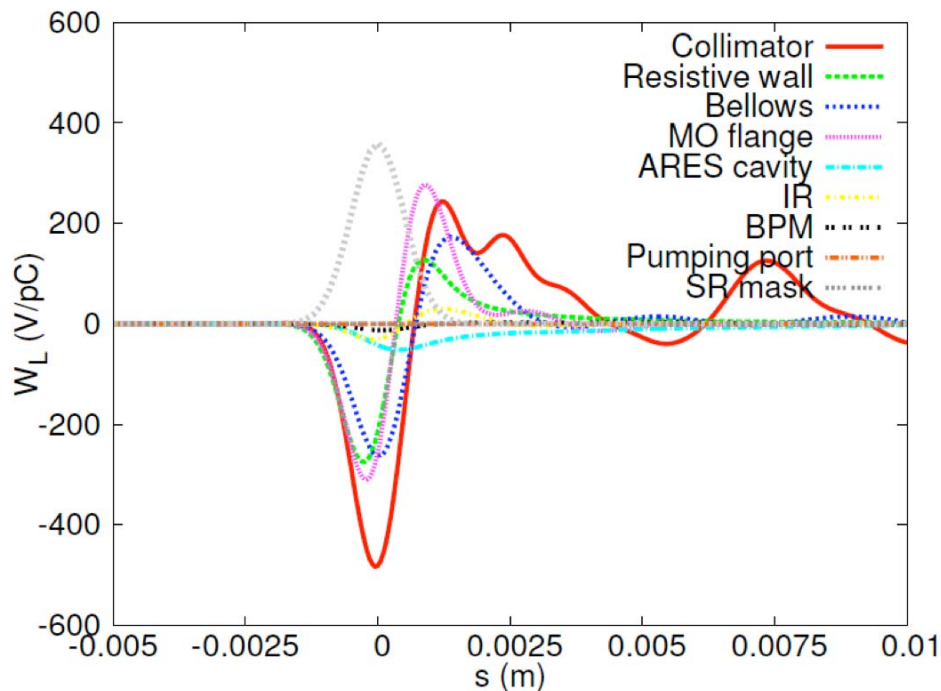

2. Impedance calculations: Results: LER

► Wake potential with nominal bunch length

- $\sigma_z = 5\text{mm}$
- Main sources: Collimators, Resistive wall, ARES cavity, Bellows, MO flanges
- CSR and CWR are not strong if no microbunching happens

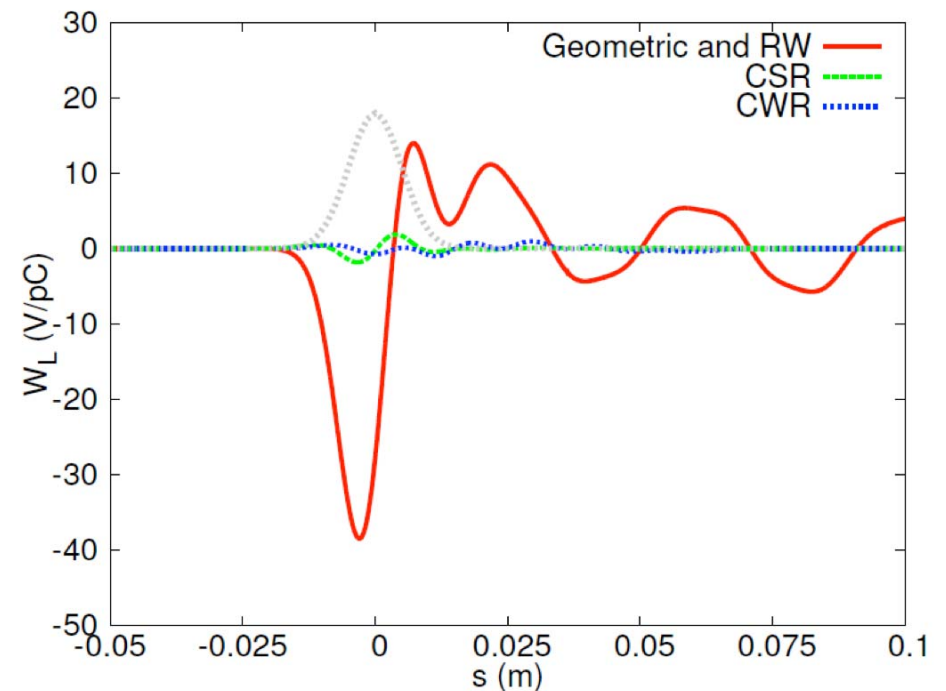
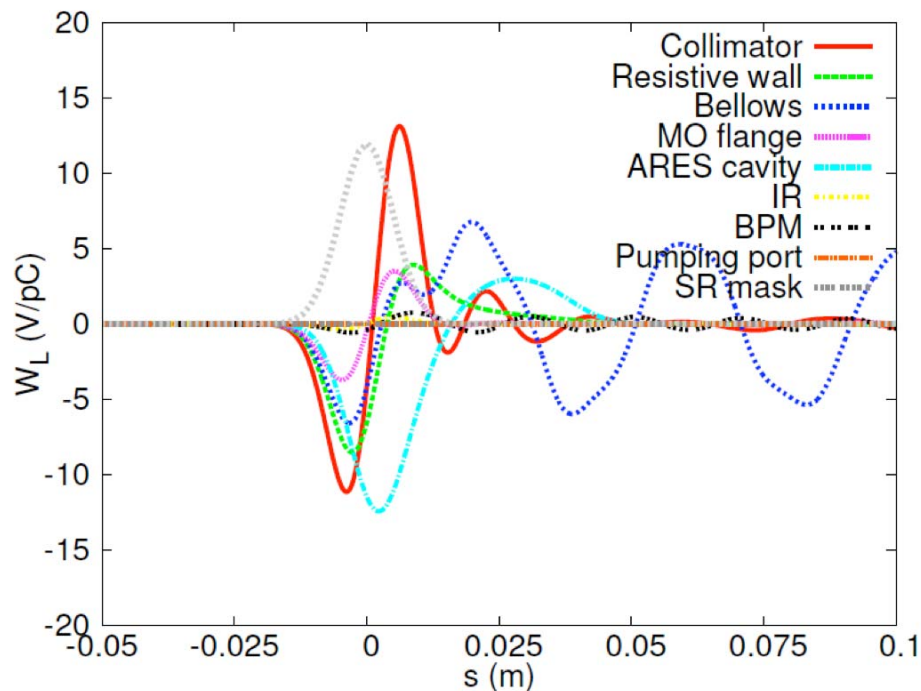

2. Impedance calculations: Results: HER

➤ Pseudo-Green wake function

- $\sigma_z=0.5\text{mm}$
- CSR: CSRZ code with rectangular chamber
- CWR (Wiggler radiation) not considered yet
- Not considered yet: Gate valves, Tapers, BxB FB BPMs

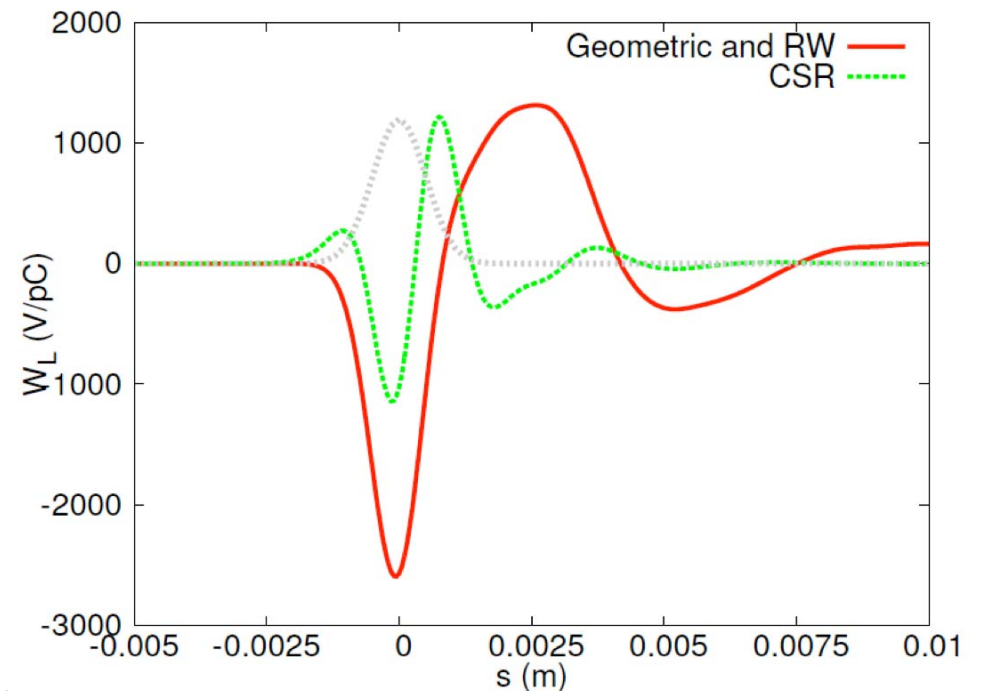
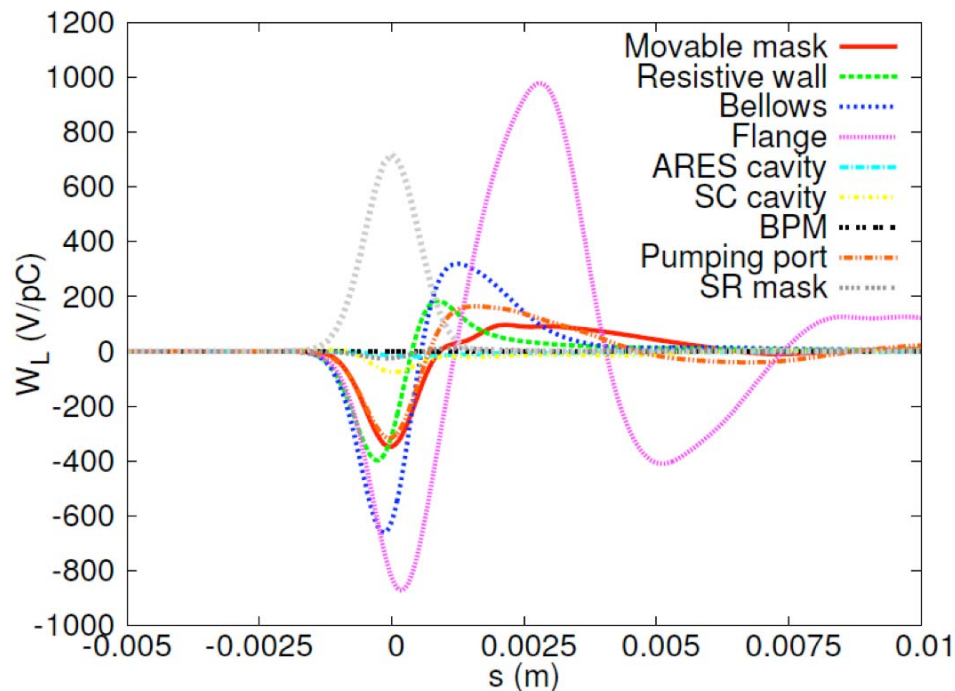

2. Impedance calculations: Results: HER

➤ Wake potential with nominal bunch length

- $\sigma_z = 5\text{mm}$
- Important sources: Movable masks, Resistive wall, Flange gaps, Bellows, SCC cavities, ARES cavities, Pumping port
- CSR is weak if no microbunching happens

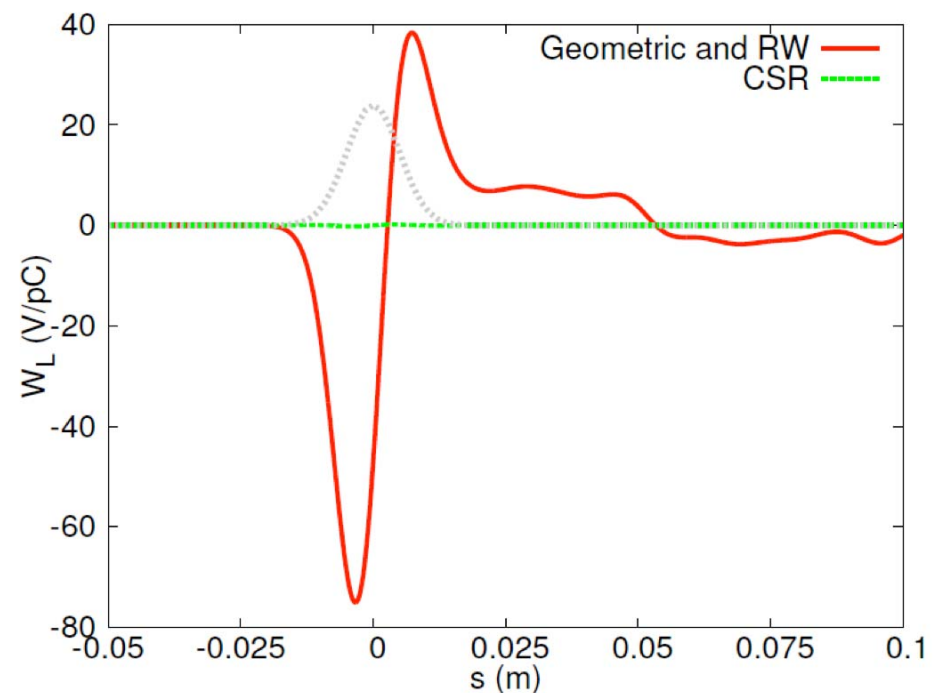
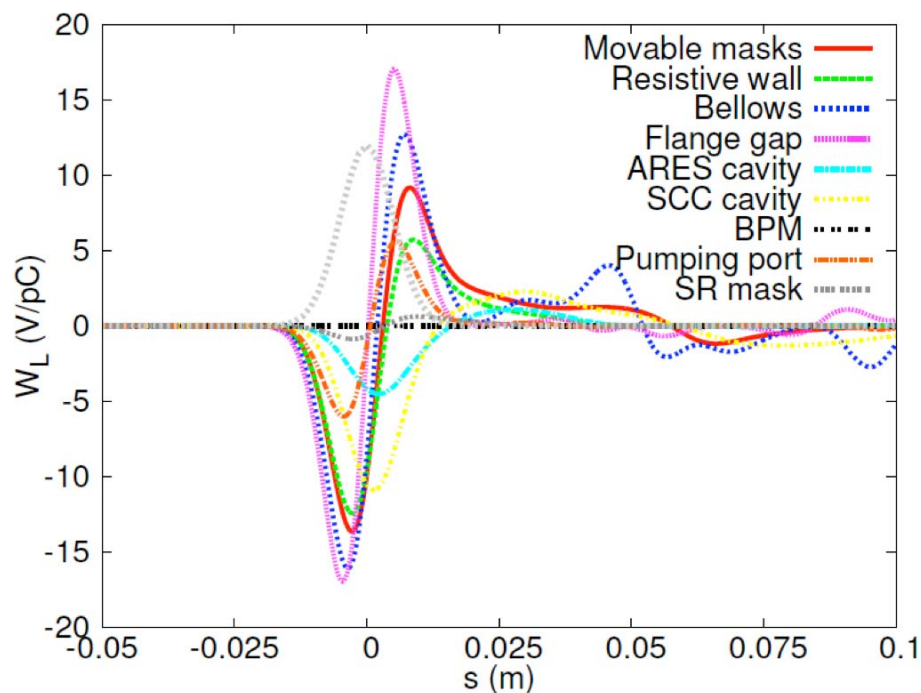

3. Loss factors and HOM power: LER

➤ Main results with $\sigma_z=6\text{mm}$ for LER:

- Total loss factor: $\sim 20 \text{ V/pC}$
- Total HOM power at full current: $\sim 1000 \text{ kW}$

Component	$k^{\dagger 1}$ [V C ⁻¹] (per 1 m)	Number of Items	Total k [V C ⁻¹]	P_1 [kW]
Resistive Wall ^{*2}	1.1×10^9	3000 m	3.3×10^{12}	170
Pumping Holes	4.3×10^{-2}	2400 m	1.0×10^6	5.2×10^{-3}
Flange	1.5×10^7	2000	3.0×10^{10}	1.6
Bellows chamber	3.0×10^9	1000	3.0×10^{12}	160
SR Mask ^{*3}	1.8×10^{-3}	1000	1.8×10^3	9.3×10^{-8}
Gate Valves	3.0×10^9	47	1.4×10^{11}	7.3
Collimators [*]	4.0×10^{10}	13	5.0×10^{11}	26
Taper	3.8×10^8	50	1.9×10^{10}	0.99
BPM	1.6×10^8	450	7.2×10^{10}	3.7
B×B FB BPM	5.9×10^8	10	5.9×10^9	0.31
FB kicker	5.0×10^{11}	1	5.0×10^{11}	26
Grooved surface	2.6×10^8	520 m	1.4×10^{11}	7.2
Clearing electrode	1.1×10^9	150 m	1.7×10^{11}	8.8
IR Chamber	8.0×10^8	1	8.0×10^8	0.041
Cavity (ARES)	4.4×10^{11}	22	9.7×10^{12}	500
Total			$\sim 20 \times 10^{12}$	~ 1000

3. Loss factors and HOM power: HER

➤ Main results with $\sigma_z=6\text{mm}$ for HER:

- Total loss factor: $\sim 30 \text{ V/pC}$
- Total HOM power at full current: $\sim 800 \text{ kW}$

Component	k^{*1} [V C ⁻¹] (per 1 m)	Number of Items	Total k [V C ⁻¹]	P_1 [kW]
Resistive Wall [†]	1.4×10^9	3000 m	4.2×10^{12}	110
Pumping Holes	7.0×10^7	1000	7.0×10^{10}	1.9
Flange	3.0×10^8	2000	6.0×10^{11}	16
Bellows chamber	3.0×10^9	1000	3.0×10^{12}	81
SR Mask ^{‡3}	2.5×10^8	1000	2.5×10^{11}	6.8
Gate Valves	3.0×10^9	41	1.2×10^{11}	3.2
Collimators ^{‡4}	2.3×10^{11}	16	3.7×10^{12}	100
Taper	3.8×10^8	20	7.6×10^9	0.21
BPM	1.6×10^8	450	7.2×10^{10}	1.9
B×B FB BPM	5.9×10^8	10	5.9×10^9	0.16
FB kicker	5.0×10^{11}	1	5.0×10^{11}	14
IR Chamber	8.0×10^8	1	8.0×10^8	0.022
Cavity (ARES)	4.4×10^{11}	8	3.5×10^{12}	95
Cavity (SCC)	1.4×10^{12}	8	1.1×10^{13}	300
Total			$\sim 30 \times 10^{12}$	~ 800

4. Single-bunch effects: Longitudinal: LER

► Simulations with input of Pseudo-Green wake:

- Use Cai-Warnock's VFP solver
- Collimators are important sources in bunch lengthening
- Simulated $\sigma_z \approx 5.8\text{mm}$ @ Design bunch current
- Simulated MWI threshold is around $NP_{th} = 17.E10$
- CSR and CWR are likely to be not important. BUT ...

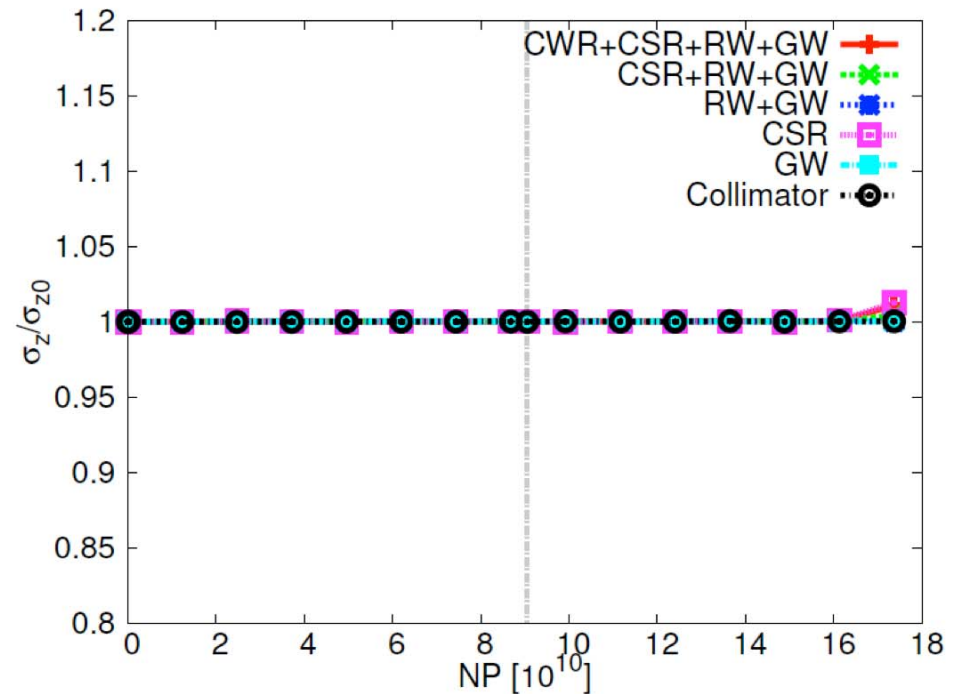
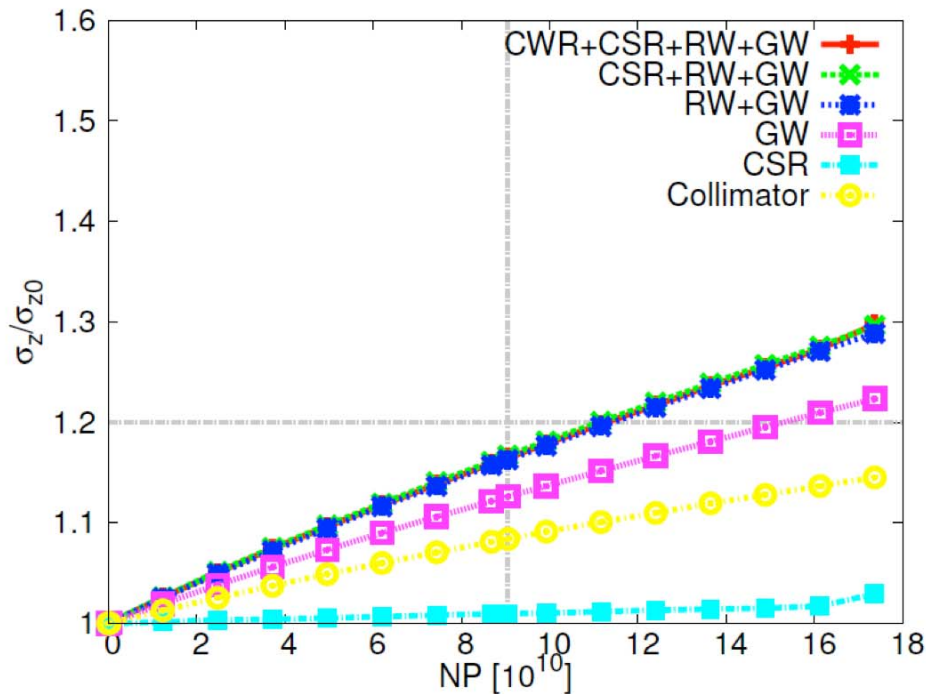

4. Single-bunch effects: Longitudinal: LER

► Simulations with input of Pseudo-Green wake:

- **BUT**, pseudo-Green wakes for CSR, CWR and RW are not good choices. => To be improved.

- Potential-well distortion => Longitudinal beam tilt => Impact on luminosity to be evaluated

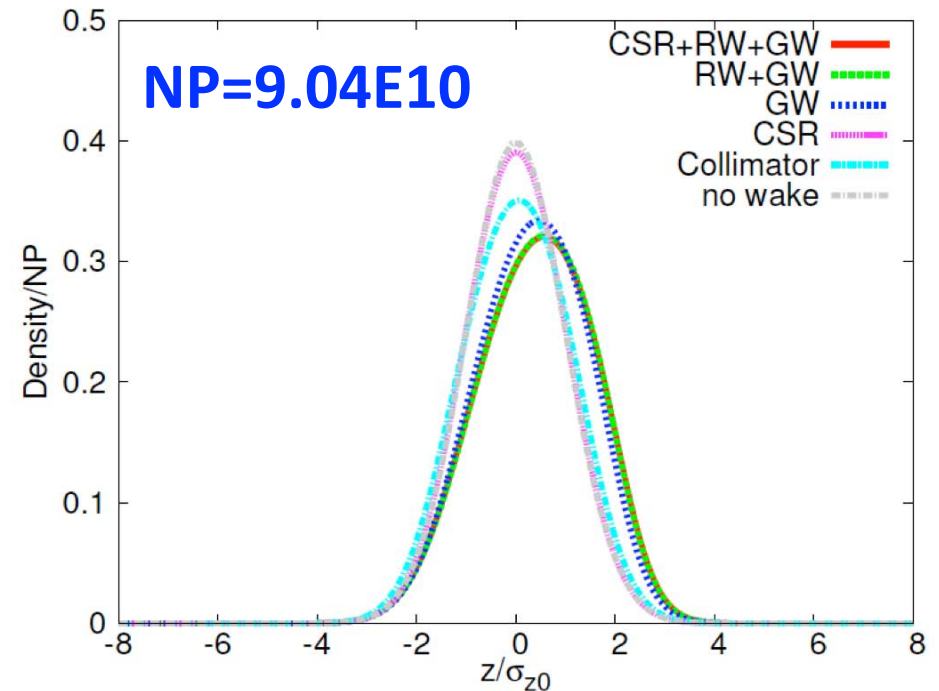
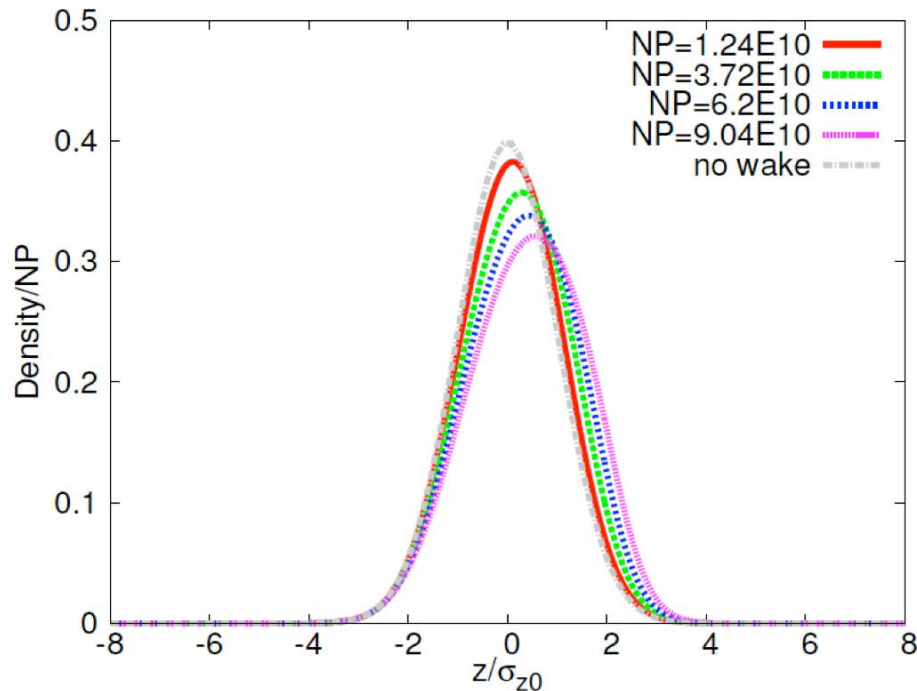

4. Single-bunch effects: Longitudinal: HER

► Simulations with input of Pseudo-Green wake:

- Use Cai-Warnock's VFP solver
- Movable mask: KEKB-type model used => To be improved
- Simulated $\sigma_z \approx 5.8\text{mm}$ @ Design bunch current
- Simulated MWI threshold is around $NP_{th} = 17.E10$
- CSR and CWR are likely to be not important.

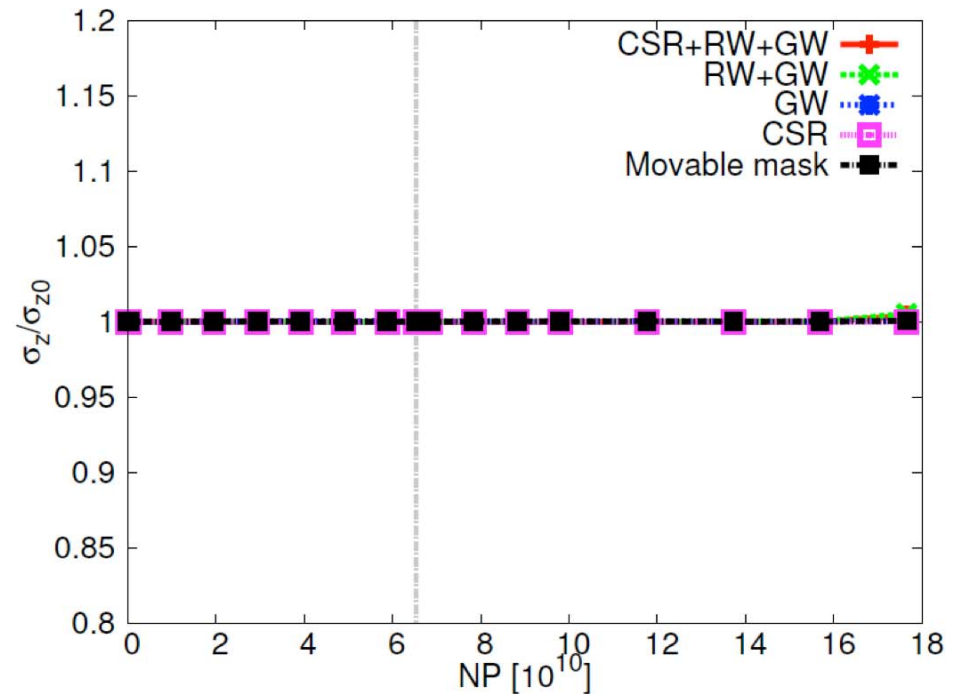
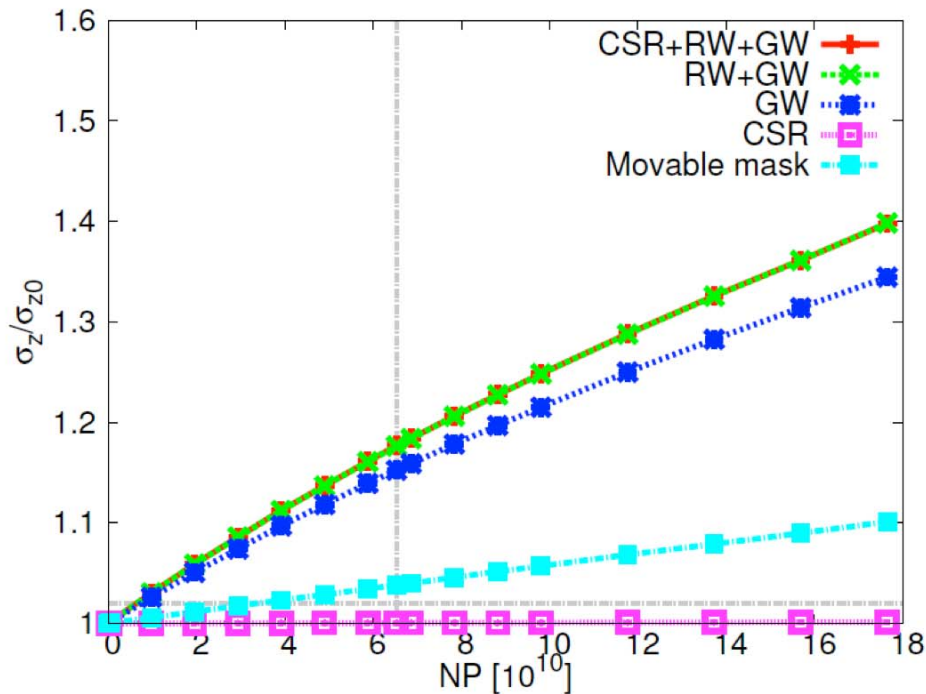

4. Single-bunch effects: Longitudinal: HER

➤ Simulations with input of Pseudo-Green wake:

- **BUT**, pseudo-Green wakes for CSR, CWR and RW are not good choices. => To be improved.

- Potential-well distortion => Longitudinal beam tilt => Impact on luminosity to be evaluated

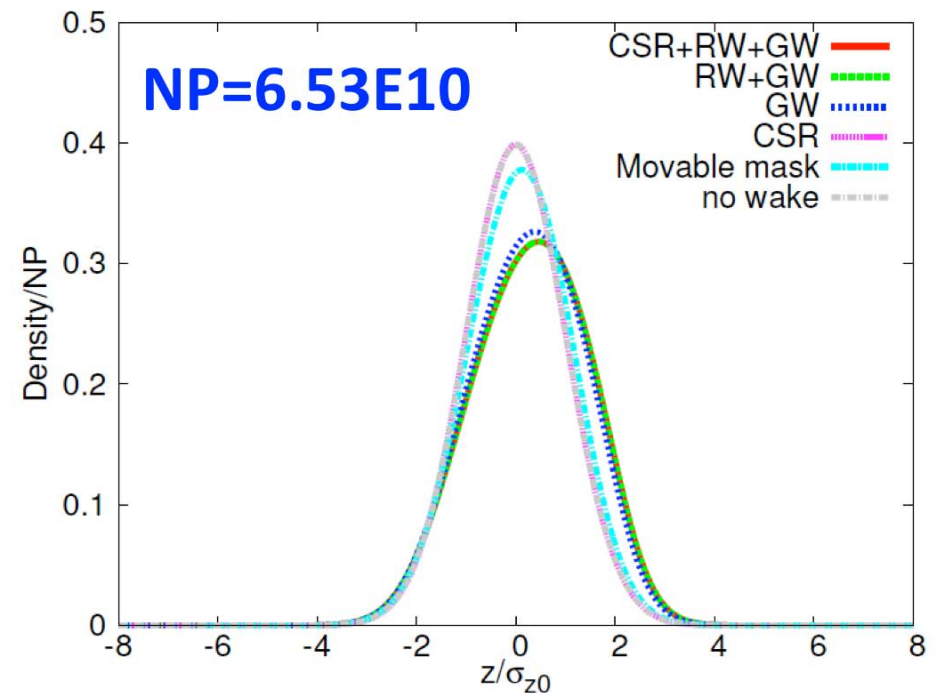
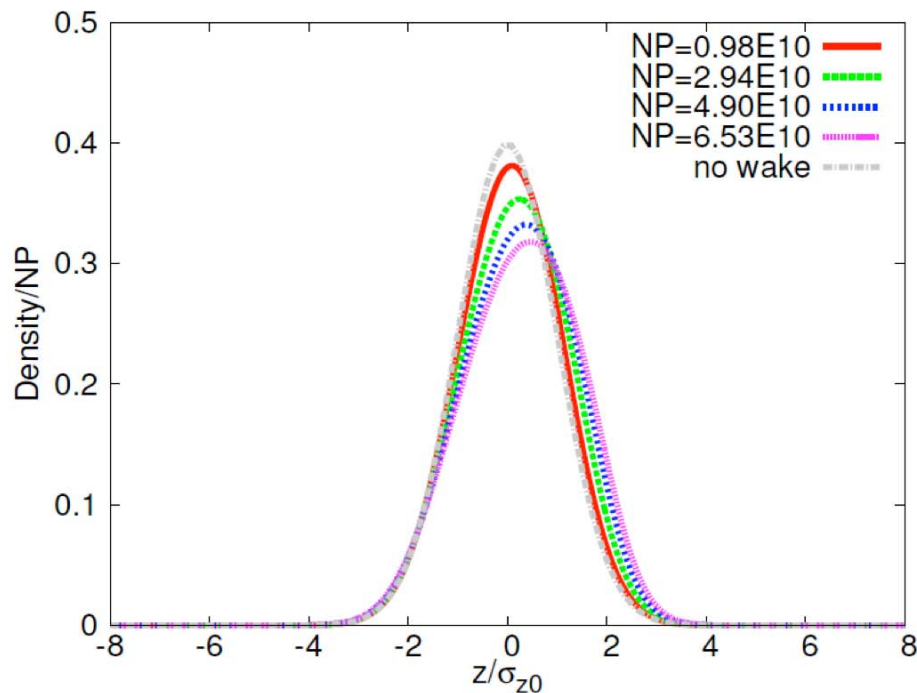

4. Single-bunch effects: Longitudinal: CSR

➤ Y. Cai's theory on CSR effects in rectangular chamber:

- Steady-state CSR model
- Square chamber lowers MWI threshold ...
- Chamber aspect ratio >2 preferred

$$N_{th} = \frac{CI_A}{ce} \frac{\alpha_p \gamma \sigma_\delta^2}{\sigma_z} \frac{\sigma_z^{4/3}}{R^{1/3}} \xi_{th}$$

$$I_A = 4\pi\epsilon_0 \frac{m_e c^3}{e} \quad \chi = \sigma_z \sqrt{\frac{R}{b^3}}$$

Parallel plates:

$$\xi_{th} = 0.5 + 0.34\chi$$

Rectangular chamber:

$$\xi = \xi_{th}\left(\chi, A = \frac{a}{b}, \frac{1}{\omega_s \tau_d}\right)$$

Scaling law of coherent synchrotron radiation in a rectangular chamber

Yunhai Cai

SLAC National Accelerator Laboratory, Menlo Park, California 94025, USA
(Received 21 October 2013; published 12 February 2014)

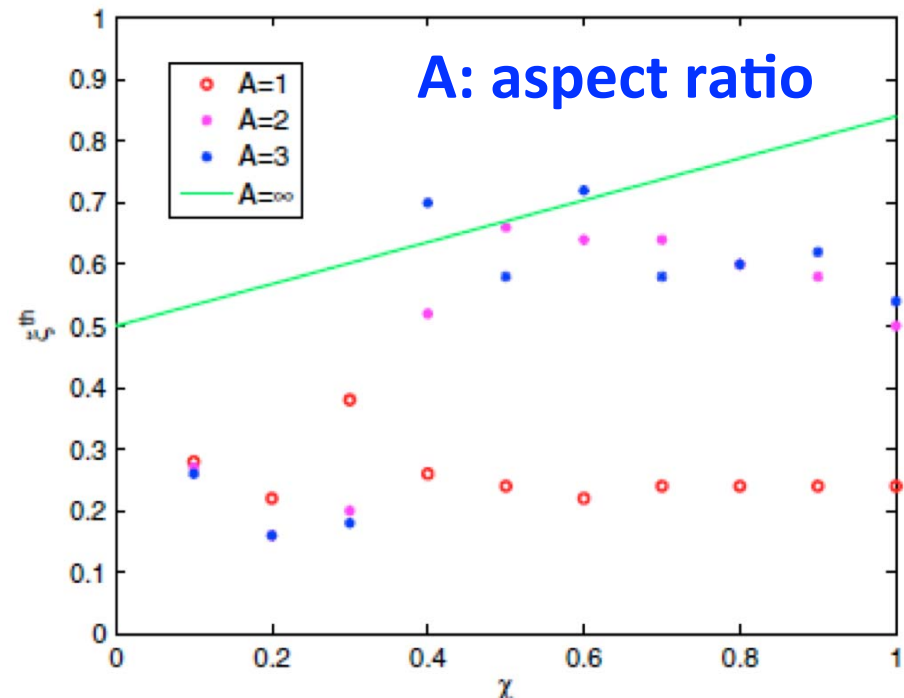

4. Single-bunch effects: Longitudinal: CSR

➤ Y. Cai's theory on CSR effects in **rectangular chamber**:

- **Applicable conditions to be validated for SuperKEKB**

	DR			LER	HER
E(GeV)	1.1			4.0	7.007
NP(10^{10})	5			9.04	6.53
b(mm)	24			90	50
a(mm)	34			90	104
R(m)	2.7/3			74.7	106
χ	1.49	1.67	2.16	1.15	1.98
$\alpha_p(10^{-4})$	141			3.25	4.55
$\sigma_\delta(10^{-4})$	5.5			8.08	6.37
$\sigma_z(\text{mm})$	6.6	7.8	11	6	5
$\xi_{\text{th}}^{\text{old}}$	1.49	1.67	2.16	1.15	2.1
$N_{\text{th}}^{\text{old}}(10^{10})$	4.4	5.2	7.6	8.8	20.2
$\xi_{\text{th}}^{\text{new}}$	0.5(?)	0.5(?)	0.5(?)	0.25	0.5
$N_{\text{th}}^{\text{new}}(10^{10})$	1.5(?)	1.6(?)	1.8(?)	1.9	4.9

4. Single-bunch effects: Longitudinal: CSR

➤ CSR at J-ARC of SuperKEKB linac:

- Impedance calculated by CSRZ
- Chamber: $a=33\text{mm}$, $b=18\text{mm}$, $R=3.643\text{m}$
- Bunch full length: 10 ps - 4 ps
- Maximum bunch charge: 5nC

J-ARC layout

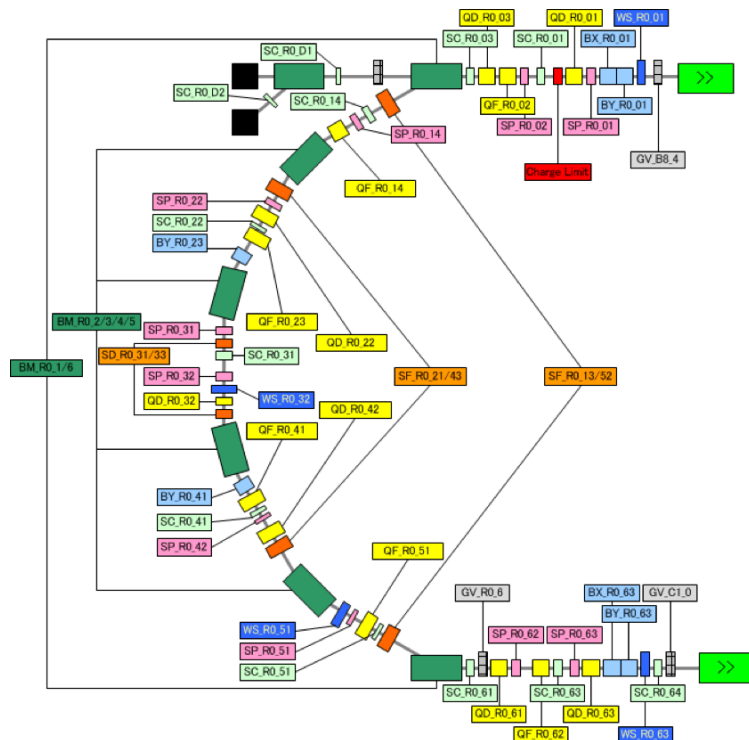

Chamber cross section

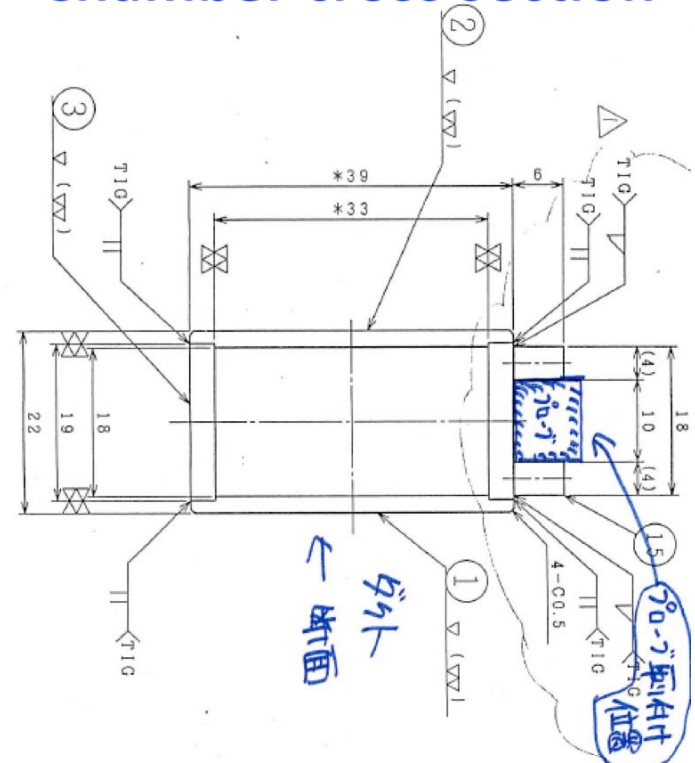

4. Single-bunch effects: Longitudinal: CSR

➤ CSR at J-ARC of SuperKEKB linac:

- Sharp peaks correspond to multi-bend CSR interference
- Bunch full width 10-4ps: Strong chamber shielding
- Tracking simulations to be done

Assume Gaussian bunch

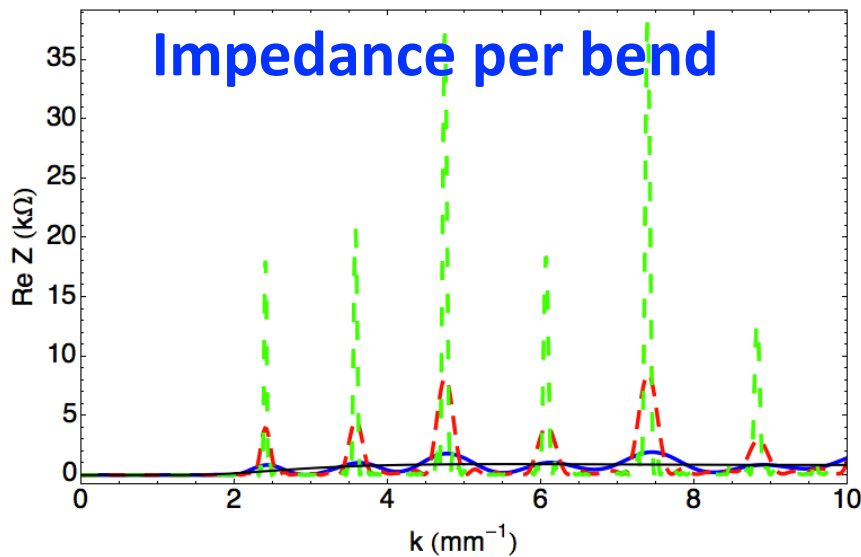

$\Delta E \approx -0.4 \text{ MeV/bend}$

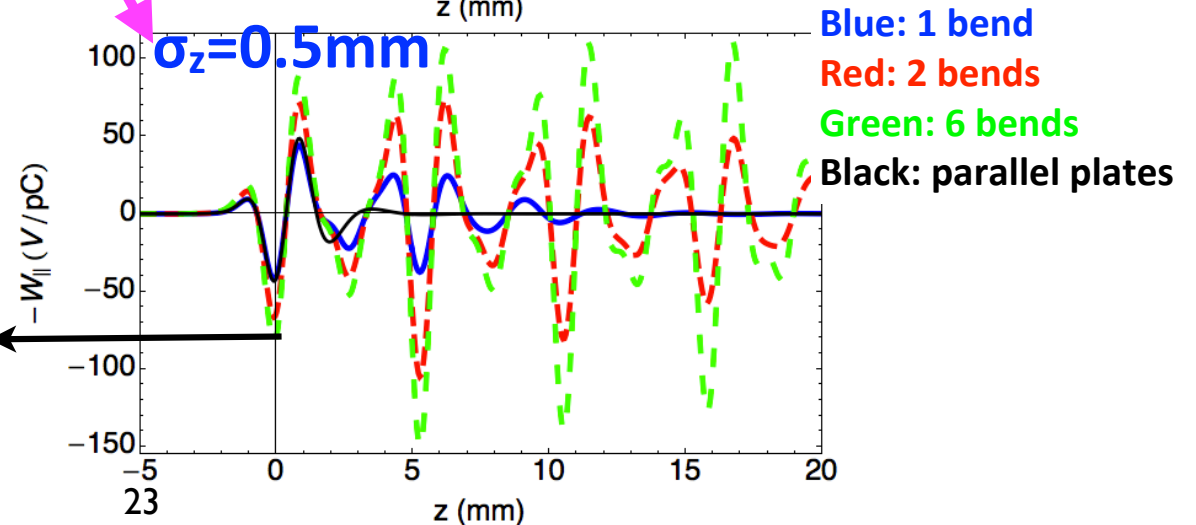
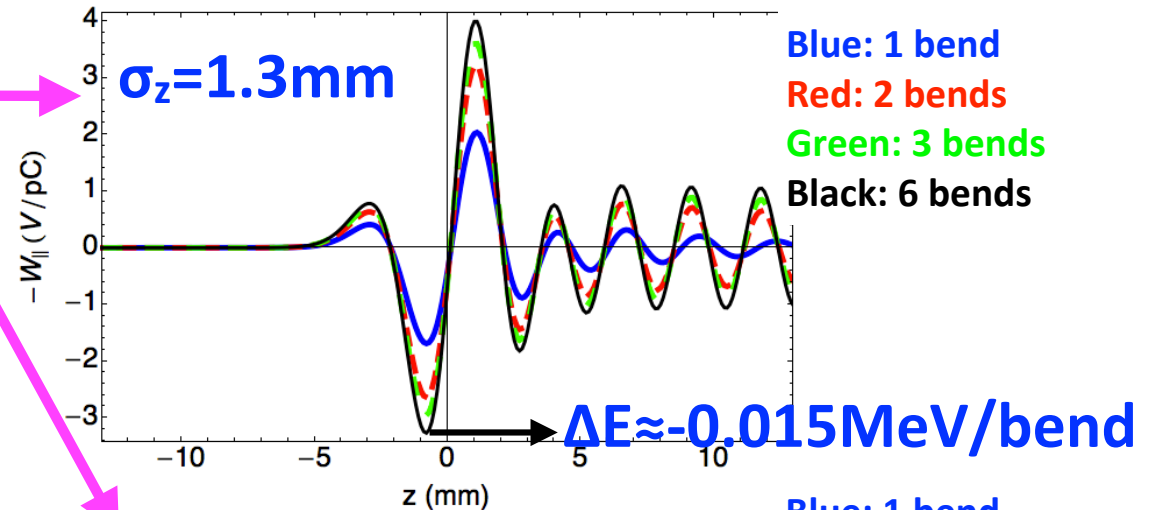

4. Single-bunch effects: Transverse: Beam tilt

➤ G. Stupakov's theory on transverse beam tilt:

- To be a concern in small emittance rings
- Asymmetric protrusion (if exists)

$$\Delta\epsilon_y = \frac{1}{4 \sin^2(\pi\nu_y)} \beta_y \theta_{\text{rms}}^2$$

$$\theta_{\text{rms}} = \frac{Ne^2}{\gamma m_0 c^2} \sqrt{\langle (W_y - \langle W_y \rangle)^2 \rangle}$$

$$\langle W_y \rangle = \int_{-\infty}^{\infty} W_y(s) \lambda(s) ds$$

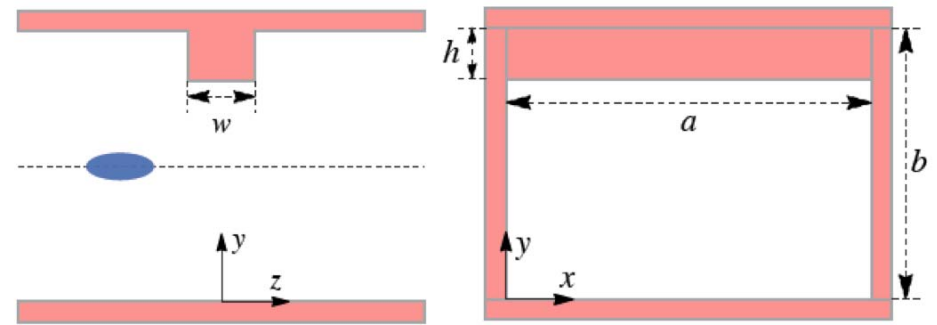
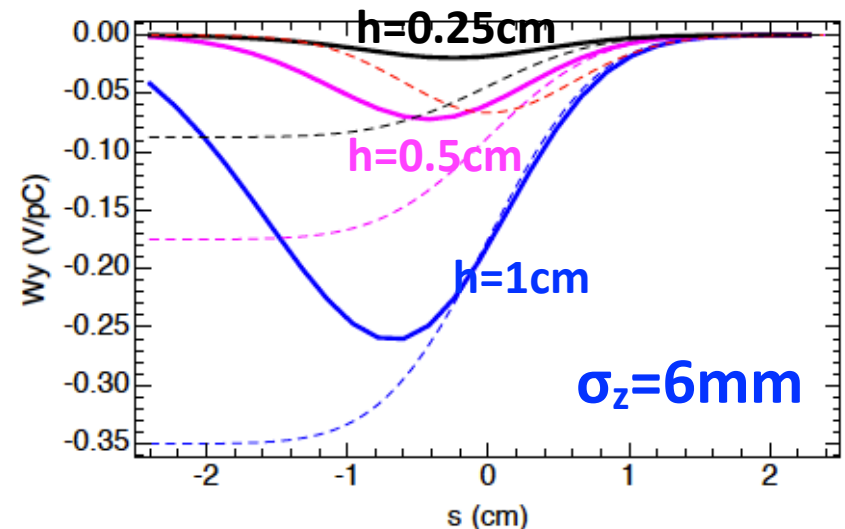

TABLE II. Emittance increase in LER of SUPERKEKB

Corrugation depth h (cm)	1	0.5	0.25
θ_{rms} (nrad)	290	77	20
$\Delta\epsilon$ (pm)	0.45	0.03	0.002



4. Single-bunch effects: Transverse: Beam tilt

➤ G. Stupakov's theory on transverse beam tilt:

- Symmetric 3D structure (like collimator) with orbit offset
- D02V1 in LER as an example: $d=-2/2\text{mm}$, $\beta_y=104.6\text{m}$
- COD DY < 0.2 mm required?

$$\Delta\epsilon_y = \frac{1}{4 \sin^2(\pi\nu_y)} \beta_y \theta_{\text{rms}}^2$$

$$\theta_{\text{rms}} = \frac{Ne^2 \Delta y}{\gamma m_0 c^2} \sqrt{\langle (W'_y - \langle W'_y \rangle)^2 \rangle}$$

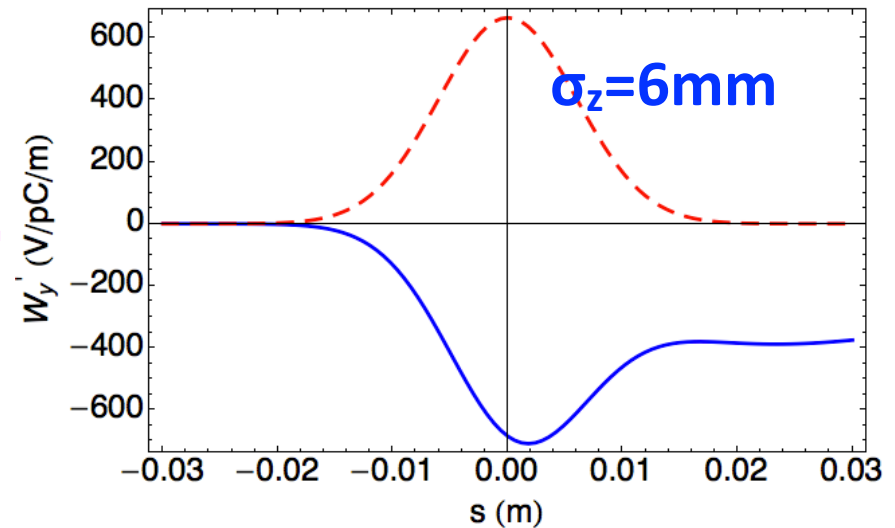
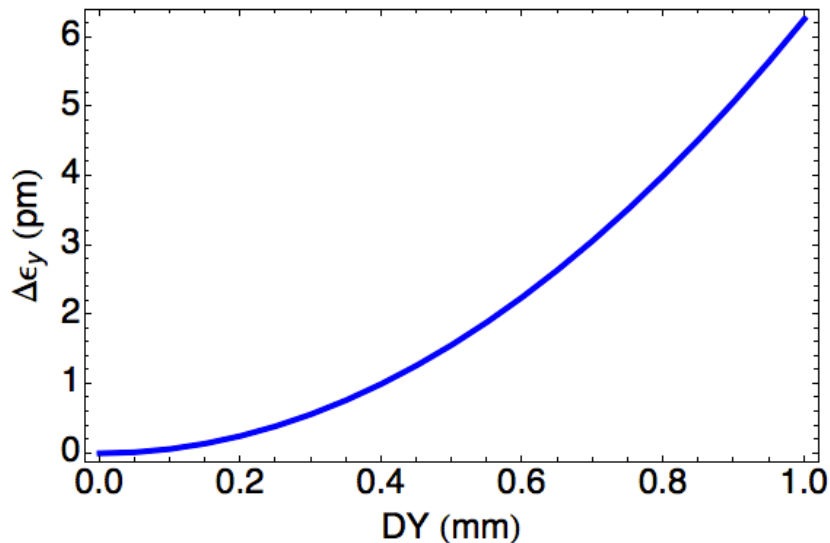
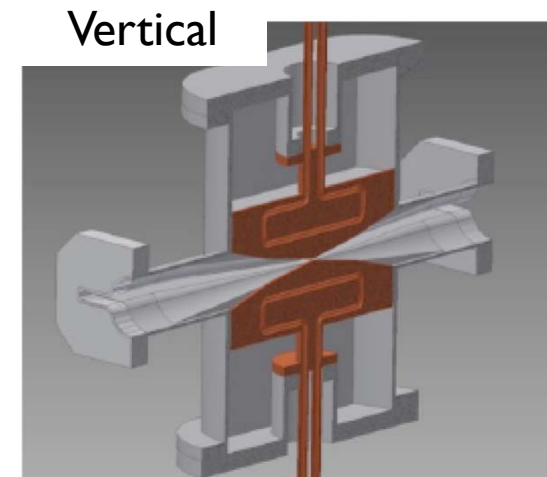

4. Single-bunch effects: TMCI: LER

- ❖ We estimated the threshold of the Transverse Mode Coupling Instability using actual β value at each collimator with $\sigma_z = 6$ mm.
- ❖ The bunch current of the design value in LER is 1.44 mA/bunch.
- ❖ A kick factor in D02V1 is quite large because of the narrow aperture (± 2 mm), and it limits the bunch current.
- ❖ We may need an another structure, such as long heads with gradual slope, for D02V1.

	TMC Threshold (mA/bunch)	
	All Closed	Actual Apertures
Horizontal	1.41	13.15
Vertical	0.96	1.25

$$I_{thresh} = \frac{C_1 f_s E / e}{\sum_i \beta_i \kappa_{\perp i} (\sigma_z)}$$

Collimator No.	d [mm]	k [V pC ⁻¹]	k _z [V pC ⁻¹ m ⁻¹]	β_x [m]	β_y [m]
D06 H1	-16.0 / +17.0	0.036	8	24.28	5.5043
D06 H2	-16.0 / +16.0	0.036	8	24.28	5.5042
D06 H3	-16.0 / +15.0	0.036	9	24.28	5.5043
D06 H4	-13.0 / +13.0	0.037	15	24.28	5.5042
D03 H1	-21.0 / +20.0	0.036	6	28.97	3.021
D03 H2	-18.0 / +20.0	0.036	7	28.97	3.021
D03 V1	-9.0 / +9.0	0.058	40	10.38	17.05
D03 V2	-9.0 / +9.0	0.058	40	10.38	17.05
D02 H1	-10.6 / +12.0	0.038	25	33.20	19.06
D02 H2	-16.0 / +20.0	0.036	8	81.01	22.01
D02 H3	-18.0 / +21.0	0.036	7	31.09	173.3
D02 H4	-13.0 / +9.0	0.04	40	45.63	6.236
D02 V1	-2.0 / 2.0	0.098	600	21.79	104.6

Lattice version:
sler_1689

5. Summary

➤ Impedance calculations

- Impedance calculations with $\sigma_z=6\text{mm}$ => Loss factors and HOM power estimation

- Longitudinal impedance calculations with $\sigma_z=0.5\text{mm}$ => Pseudo-Green wake => Simulations of MWI

- Transverse impedance calculations with $\sigma_z=0.5\text{mm}$ => **Catalogued** but need COD for further instability analysis

➤ Longitudinal single-bunch effects

- $\sigma_z \approx 5.8\text{mm}$ @ Design bunch current for both LER and HER

- CSR remains to be a concern

- MWI threshold: Need more (very) careful simulations

➤ Transverse single-bunch effects

- Beam tilt due to transverse impedance examined

- TMCI due to collimators remains to be a concern

6. Future plan

➤ Refining pseudo-Green wake function

- Consider all impedance sources
- Update impedance calculations while hardware designs change
- Double-check finished impedance calculations
- Proper models of CSR, CWR, and RW: Point-charge wake function

➤ Numerical simulations

- Careful simulations of MWI via Vlasov solver (Very tricky and request high computing power, especially with CSR!)
- Tracking simulations of beam tilt and TMCI
- Impact of single-bunch effects on luminosity performance

➤ Collaborations

- Y. Cai: CSR, MWI, ...
- G. Stupakov: Impedance calculations, beam instabilities, ...

➤ Prepare beam measurements in 2015

- Bunch lengthening, impedance, space charge, ecloud, fast ion, ...

Thanks for your attention!